

PRECAST CONCRETE CURB INLET

24" DIAMETER ACCESS INLET BOX DETAIL

B-5, B-10, B-15 & B-20 INLETS PROVIDED WITH WINGS FOR B-25, ETC. WHERE SUITABLE (SEE DRAWING FOR WING DETAIL)
 MULTIPLE INLETS MAY BE PROVIDED WITH A SHORT "FEEDER" PIPE FOR CONNECTING INLETS TO PROVIDE LARGER INLET CAPACITY AS REQUIRED.
****CURB INLETS ARE ALSO AVAILABLE AS SPECIAL ORDER ITEMS WITH AN INSIDE WIDTH OF 3'-6"**

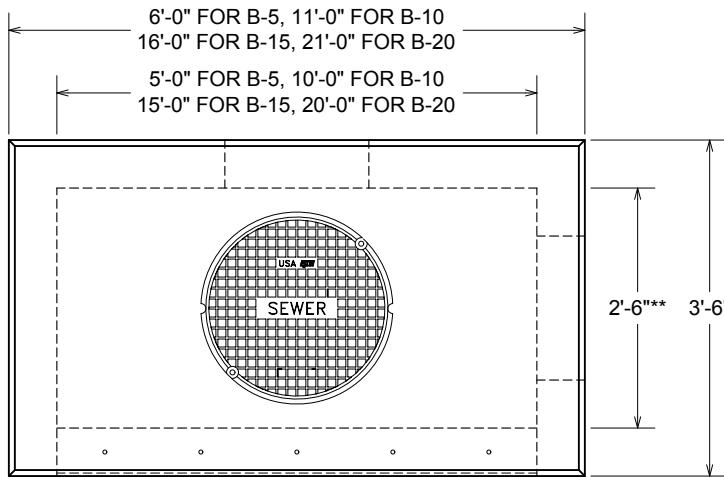

PLAN VIEW

- VCP ITEM #B-5 (24) CURB INLET
- VCP ITEM #B-10 (24) CURB INLET
- VCP ITEM #B-15 (24) CURB INLET
- VCP ITEM #B-20 (24) CURB INLET

CONTRACTOR TO PLACE FLOW INVERT AS REQUIRED

WEIGHTS:

- B-5 TOP: ~3,220 LBS.
- B-10 TOP: ~5,300 LBS.
- B-15 & B-20 JOINT LOCATIONS VARY AS REQ'D.
- BOX WEIGHTS VARY WITH SIZE & DEPTH

5"X5"X $\frac{3}{8}$ " ANGLE IRON CAST IN FRONT FACE OF TOP SECTION. ANGLE IRON ANCHORED INTO FACE OF TOP SECTION BY USING #4 L-SHAPED REBARS WITH ONE 6" & ONE 18" LEG. THE 6" LEG OF L BARS TO BE WELDED TO OPPOSITE LEGS OF ANGLE IRON @ 12" O.C., THE 18" LEG OF L BARS TO PROJECT INTO TOP SECTION

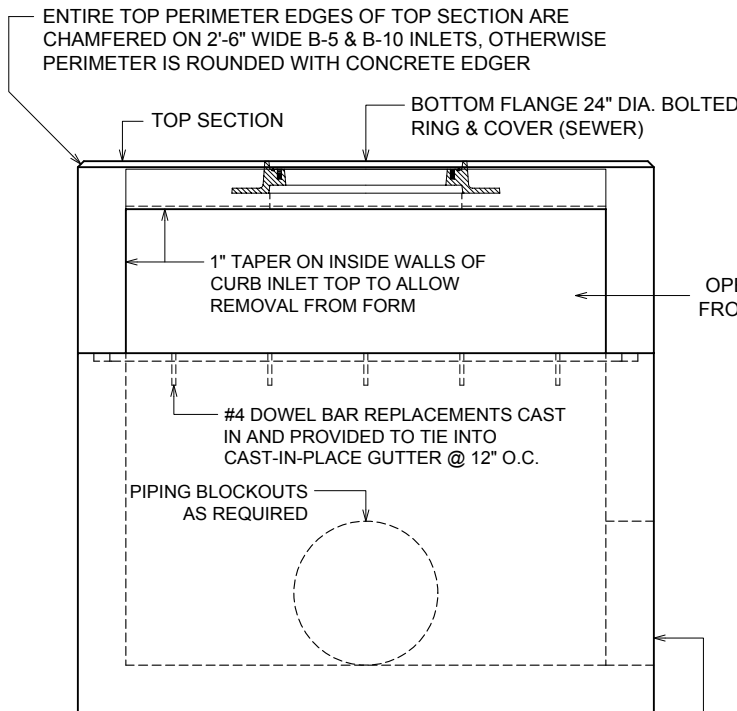

FRONT VIEW

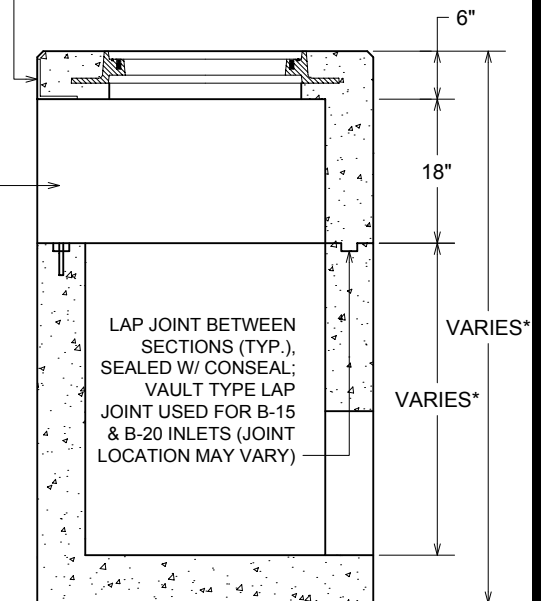

SECTION VIEW

NOTES:

- CONCRETE: 5,000 P.S.I. MINIMUM
- REINFORCING: GRADE 60 MINIMUM
- DESIGNED FOR AASHTO HS-20-44 LOADINGS
- ALL WALL THICKNESSES TO BE 6" (MINIMUM)
- *BOX DEPTH UP TO 4'-0" I.D.
- *INTERMEDIATE SECTION(S) AVAILABLE FOR INCREASED DEPTH

ACTUAL DIMENSIONS OF CONCRETE PRODUCTS MAY VARY SLIGHTLY



B-5 - B-20 24-INCH CURB INLET.DWG
 DATE CREATED: 11/05
 UPDATED: 10/10

12650 Tucson Street • Henderson, Colorado 80640 • 303-659-3747, Fax 303-659-1333
 2671 South Greeley Hwy • Cheyenne, Wyoming 82007 • 307-634-0695, Fax 307-634-0694
 10021 Amarillo Blvd East • Amarillo, Texas 79108 • 806-374-3747, Fax 806-335-3717

PRECAST CONCRETE CURB INLET

WING DETAIL

(2) 3/4" NATURAL COARSE THREAD DOWELS PROVIDED IN EACH WING BOTTOM SECTION FOR VERTICAL ALIGNMENT & TO HELP PULL WING & BOX TOGETHER, DOWELS TO PROTRUDE 10" FROM WINGS BOTTOM SECTION TO FIT INTO THE 2 HOLES CAST IN THE INLET BOX, WING BOTTOM TO HAVE OPENING IN END WALL TO MATCH OPENING IN CURB INLET BOTTOM SECTION

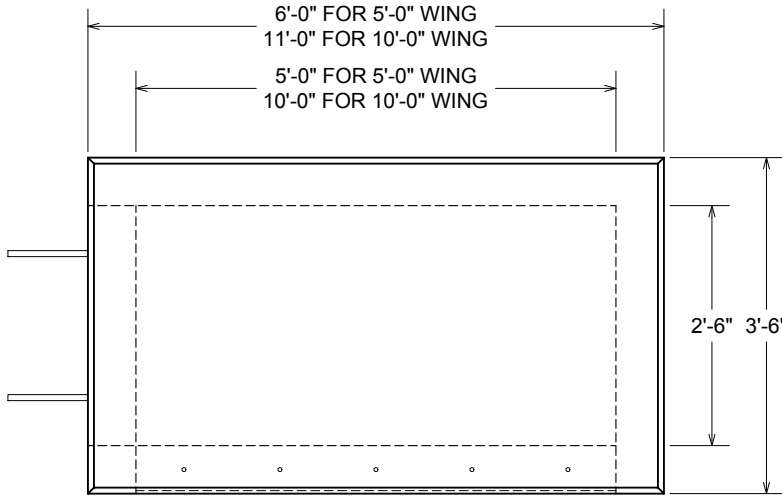

PLAN VIEW

VCP ITEM - B-5 CURB INLET WING
VCP ITEM - B-10 CURB INLET WING

CONTRACTOR TO PLACE FLOW INVERT AS REQUIRED, CONTRACTOR TO FILL JOINT BETWEEN INLET & WING WITH NON-SHRINK GROUT

5"X5"X3/8" ANGLE IRON CAST IN FRONT FACE OF TOP SECTION. ANGLE IRON ANCHORED INTO FACE OF TOP SECTION BY USING #4 L-SHAPED REBARS WITH ONE 6" & ONE 18" LEG. THE 6" LEG OF L BARS TO BE WELDED TO OPPOSITE LEGS OF ANGLE IRON @ 12" O.C., THE 18" LEG OF L BARS TO PROJECT INTO TOP SECTION

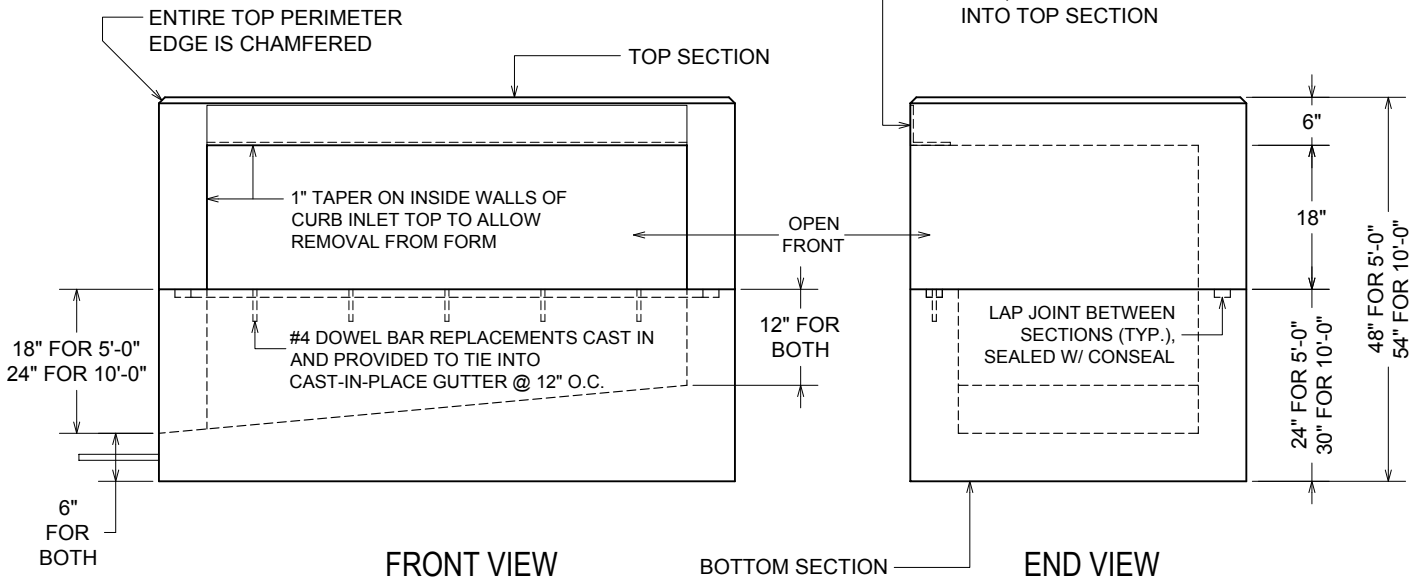

FRONT VIEW

BOTTOM SECTION

END VIEW

NOTES:

- CONCRETE: 5,000 P.S.I. MINIMUM
- REINFORCING: GRADE 60 MINIMUM
- DESIGNED FOR AASHTO HS-20-44 LOADINGS
- ALL WALL THICKNESSES TO BE 6" (MINIMUM)

WEIGHTS:

- 5' WING BOTTOM: ~5,400 LBS.
- 5' WING TOP: ~3,400 LBS.
- 10' WING BOTTOM: ~9,000 LBS.
- 10' WING TOP: ~5,400 LBS.

ACTUAL DIMENSIONS OF CONCRETE PRODUCTS MAY VARY SLIGHTLY



B-5 & B-10 CURB INLET WING.DWG
 DATE CREATED: 11/05
 UPDATED: -----

12650 Tucson Street • Henderson, Colorado 80640 • 303-659-3747, Fax 303-659-1333
 2671 South Greeley Hwy • Cheyenne, Wyoming 82007 • 307-634-0695, Fax 307-634-0694
 10021 Amarillo Blvd East • Amarillo, Texas 79108 • 806-374-3747, Fax 806-335-3717

www.vaughnconcreteproducts.com