

PRECAST CONCRETE SAMPLING BASIN

18" I.D. X 17" HIGH INSIDE DIMENSIONS
VCP ITEM #SAMPLING BASIN

APPROXIMATE WEIGHTS:

- BOTTOM BASIN SECTION: 260 LBS.
- LID W/ HDPE: 180 LBS.
- CAST IRON RING: 33 LBS.
- CAST IRON COVER: 34 LBS.

PLAN VIEW

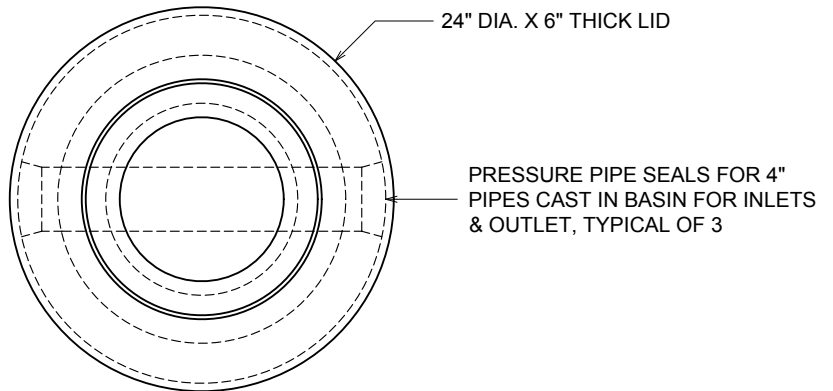

ELEVATION

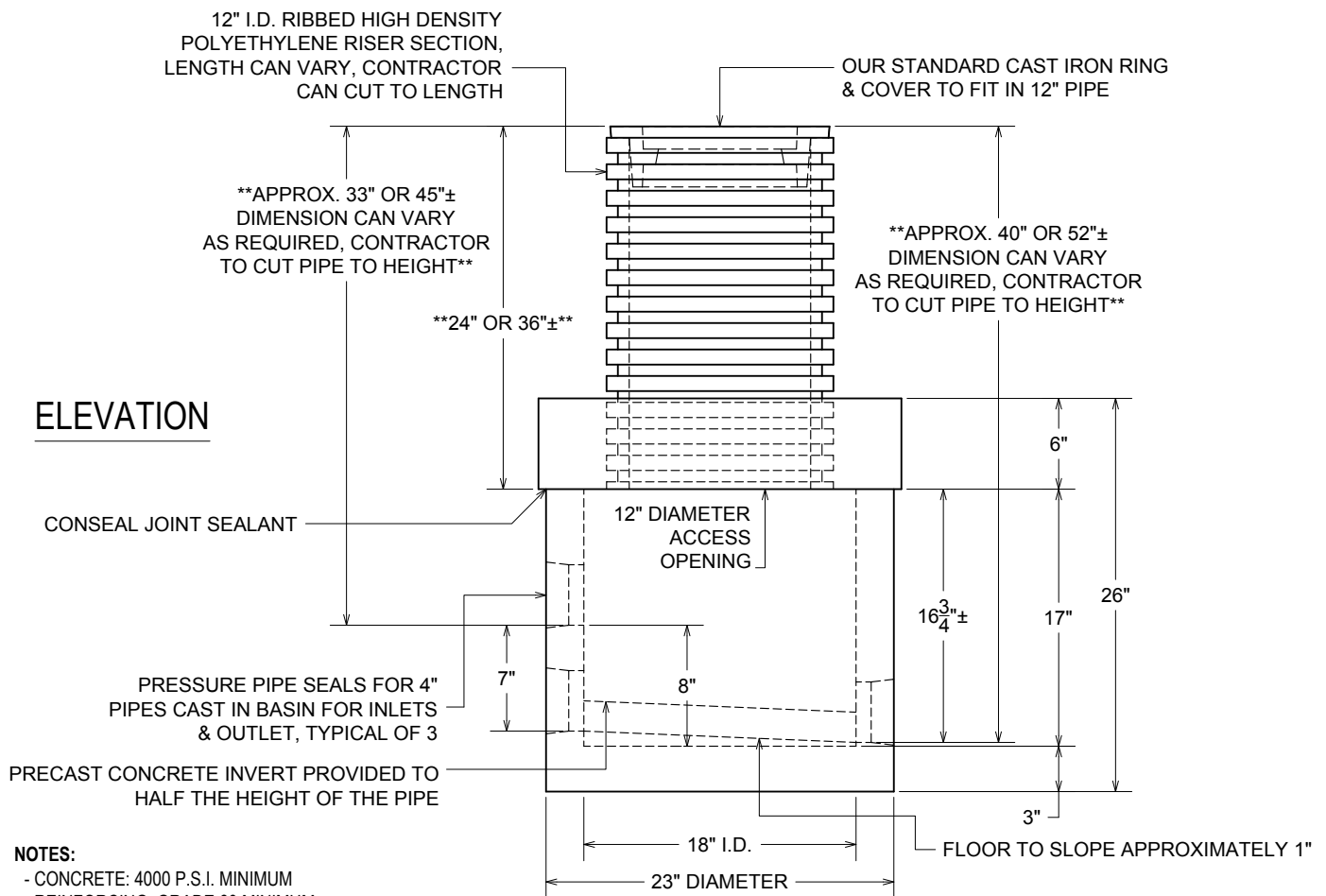

NOTES:

- CONCRETE: 4000 P.S.I. MINIMUM
 - REINFORCING: GRADE 60 MINIMUM
 - SUITABLE FOR AASHTO HS-20-44 LOADINGS WHEN PLACED ON PROPERLY PREPARED BASE & BACKFILLED TO CREATE A SOIL ENVELOPE AROUND HDPE PIPE
- ACTUAL DIMENSIONS OF CONCRETE PRODUCTS MAY VARY SLIGHTLY

FOR DEEPER APPLICATIONS THE 12" I.D. RIBBED HIGH DENSITY POLYETHYLENE RISER SECTION CAN BE PROVIDED WITH LENGTH AS REQUIRED & THE INLET CAN BE FIELD PLACED AND SEALED INTO THE 12" I.D. RISER SECTION

DRAWING NOT TO SCALE

SAMPLING BASIN.DWG
DATE CREATED: 11/03
UPDATED: 12/11

vaughn concrete products, inc.

12650 Tucson Street • Henderson, Colorado 80640 • 303-659-3747, Fax 303-659-1333
2671 South Greeley Hwy • Cheyenne, Wyoming 82007 • 307-634-0695, Fax 307-634-0694
10021 Amarillo Blvd East • Amarillo, Texas 79108 • 806-374-3747, Fax 806-335-3717

www.vaughnconcreteproducts.com