

PRECAST CONCRETE GREASE INTERCEPTOR

1500 GALLON CAPACITY
WITH TOP FOR TRAFFIC
STANDARD FOR LUBBOCK & ODESSA, TX

IT IS THE EXCAVATOR'S OR INSTALLER'S RESPONSIBILITY TO REQUEST OUR **INSTALLATION GUIDELINES** PRIOR TO INSTALLING THIS TANK

GREASE INTERCEPTOR PREVENTS GREASE FROM ENTERING COMMUNITY SEWAGE COLLECTION SYSTEM & CAUSING FREQUENT LINE PLUGGING

LARGE ACCESS OPENINGS PROVIDE EASIER PUMPING & MAINTENANCE

2 COMPARTMENT TANK WITH APPROXIMATELY 60% OF CAPACITY ON INLET SIDE

WITHSTANDS UP TO 6' OF BURY, RISERS ARE AVAILABLE FOR INLET & OUTLET

OPTIONS:

- 24" I.D. MANHOLE RISERS AVAILABLE IN 2", 3", 4", 6", 8" OR 12" HEIGHTS
- 18" ID CENTER ACCESS CONCRETE RISERS:
 - 10 $\frac{5}{8}$ " TALL FOR USE w/6" TALL MH RISER
 - 16 $\frac{5}{8}$ " TALL FOR USE w/12" TALL MH RISER
 - 4' TALL RCP SECTION FOR CONTRACTOR TO CUT TO SPECIFIC HEIGHTS
- GAS TIGHT CAST IRON RINGS & COVERS

4" THICK WALLS & FLOOR, 9" THICK ROOF
*NOTE: WALLS & DIVIDER DO TAPER, THICKNESSES DO DECREASE TO ALLOW FOR FORM REMOVAL; THE AVG. WALL & DIVIDER THICKNESSES ARE LISTED

OUR STANDARD 24" DIAMETER CAST IRON RINGS & COVERS, TYP. OF 2

CONSEAL JOINT SEALANT, OR CONTRACTOR TO GROUT

PIPING BLOCKOUTS WITH POLYLOK PIPE SEALS CAST IN TANK FOR INLET & OUTLET PIPING (TYPICAL)

CONTRACTOR'S 4" PIPES

VCP SUPPLIED 4" SCH 40 INLET & OUTLET TEES & CROSSOVER TEES

CONSEAL JOINT SEALANT

TANK WEIGHTS:

- COMPLETE INTERCEPTOR : 16,800 LBS.

DIGGING SPECIFICATIONS:

- 58" BELOW THE INLET
- EXCAVATION TO BE 6 $\frac{1}{2}$ ' WIDE X 14' LONG
- SEE OUR *INSTALLATION GUIDELINES* PRIOR TO INSTALLING THIS TANK

CONCRETE : 4,000 P.S.I. (MINIMUM)
REINFORCING : REBAR & WELDED WIRE FABRIC

ACTUAL DIMENSIONS OF CONCRETE PRODUCTS MAY VARY SLIGHTLY

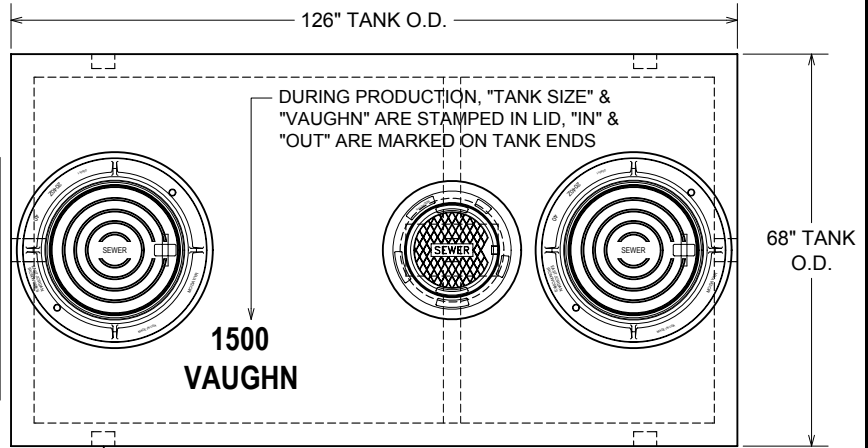

PLAN VIEW

PIPING KNOCKOUTS 16" FROM END OF TANK TO CENTER OF KNOCKOUT TO ALLOW FOR CONCRETE TO BE BROKEN OUT TO ALLOW FOR SIDE INLET OR OUTLET PIPE AT SAME HEIGHT AS STANDARD INLET & OUTLET, TYP. OF 4

APPROVED BY: _____

DATE: _____

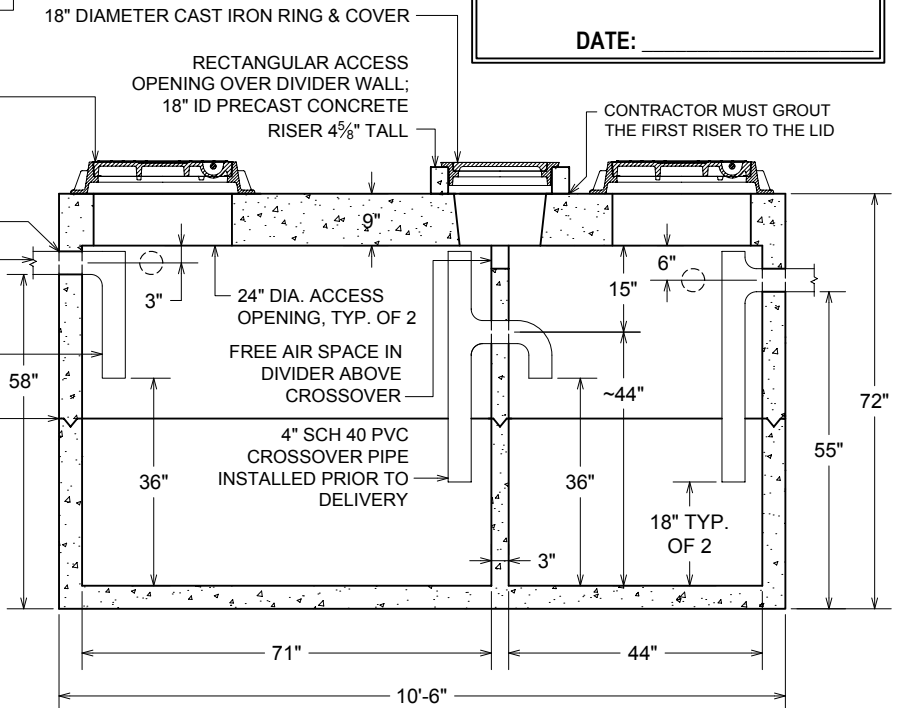

SECTION VIEW

DRAWING IS NOT TO SCALE

1500 GAL GI, TRAFFIC-LUBBOCK.DWG
DATE CREATED: 11 / 4
UPDATED: 12 / 11

