

PRECAST CONCRETE CONE ANCHOR

MEETS MOST PUBLIC SERVICE COMPANIES' SPECIFICATIONS

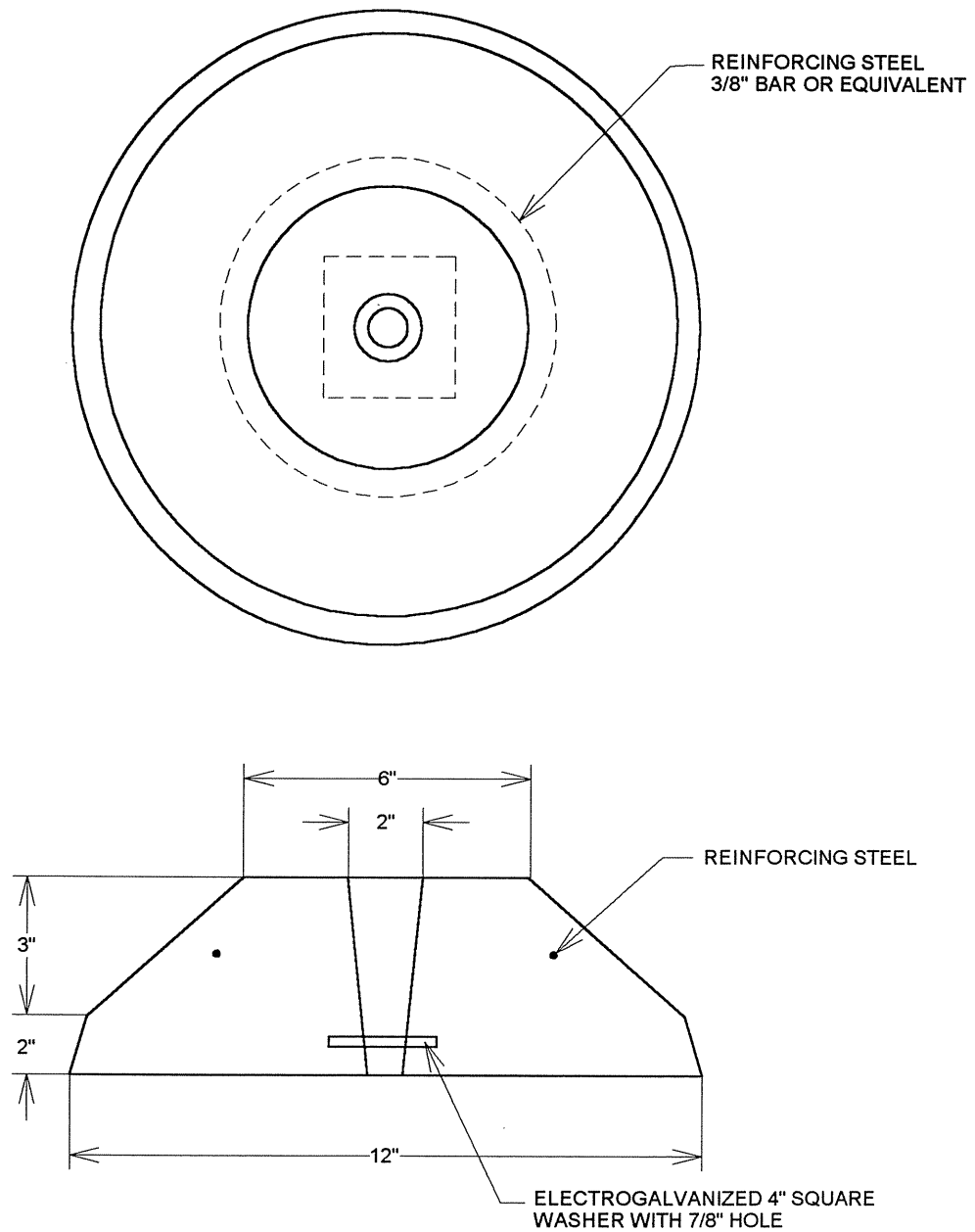

UNIT WEIGHTS APPROXIMATELY 34 LBS.

CONCRETE: 4000 P.S.I. MINIMUM
REINFORCING: GRADE 60 MINIMUM

DRAWING IS NOT TO SCALE
ACTUAL DIMENSIONS OF CONCRETE PRODUCTS MAY VARY SLIGHTLY

vaughn
concrete products, inc.

UPDATED 12/99
CATANCHOR12.SKF

12650 Tucson Street - Henderson, Colorado 80640 - 303-659-3747, Fax 303-659-1333
2671 So. Greeley Hwy - Cheyenne, Wyoming 82007 - 307-634-0695, Fax 307-634-0694
10021 Amarillo Blvd., East - Amarillo, Texas 79108 - 806-374-3747, Fax 806-335-3717