

PRECAST CONCRETE BELOW GROUND (BG)

# STORM SHELTER-RECTANGULAR

LOCALLY MANUFACTURED, PRECAST CONCRETE SHELTER WITH HATCH,  
BOTH CERTIFIED TO MEET NSSA STANDARD

STANDARD SQUARE SIZES ARE SHOWN IN THE CHART BELOW  
(OTHER SIZES ARE AVAILABLE IN EVEN FOOT INCREMENTS BY SPECIAL ORDER ONLY)

VCP ITEM #	INSIDE WIDTH	INSIDE LENGTH	OUTSIDE WIDTH	OUTSIDE LENGTH	INSIDE HEIGHT	NUMBER OF 6" VENTS	SIZE OF EXCAVATION
	A	B	C	D			
VCP #SS-50120-BGH	5'-0"	12'-0"	6'-0"	13'-0"	7'-0"	3	9'WX16'LX7'D**
VCP #SS-6080-BGH	6'-0"	8'-0"	7'-0"	9'-0"	7'-0"	2	10'WX12'LX7'D**
VCP #SS-60120-BGH	6'-0"	12'-0"	7'-0"	13'-0"	7'-0"	3	10'WX16'LX7'D**
VCP #SS-60160-BGH	6'-0"	16'-0"	7'-0"	17'-0"	7'-0"	4	10'WX20'LX7'D**
VCP #SS-60180-BGH	6'-0"	18'-0"	7'-0"	19'-0"	7'-0"	4	10'WX22'LX7'D**
VCP #SS-60240-BGH	6'-0"	24'-0"	7'-0"	25'-0"	7'-0"	6	10'WX28'LX7'D**
VCP #SS-80100-BGH	8'-0"	10'-0"	9'-0"	11'-0"	7'-0"	3	12'WX14'LX7'D**
VCP #SS-80120-BGH	8'-0"	12'-0"	9'-0"	13'-0"	7'-0"	4	12'WX15'LX7'D**
VCP #SS-100120-BGH	10'-0"	12'-0"	11'-0"	13'-0"	7'-0"	5	14'WX16'LX7'D**

DEPTH OF EXCAVATION TO ALLOW FOR A MINIMUM OF 6" OF AGGREGATE TO FACILITATE DRAINAGE BELOW THE SHELTER\*\*

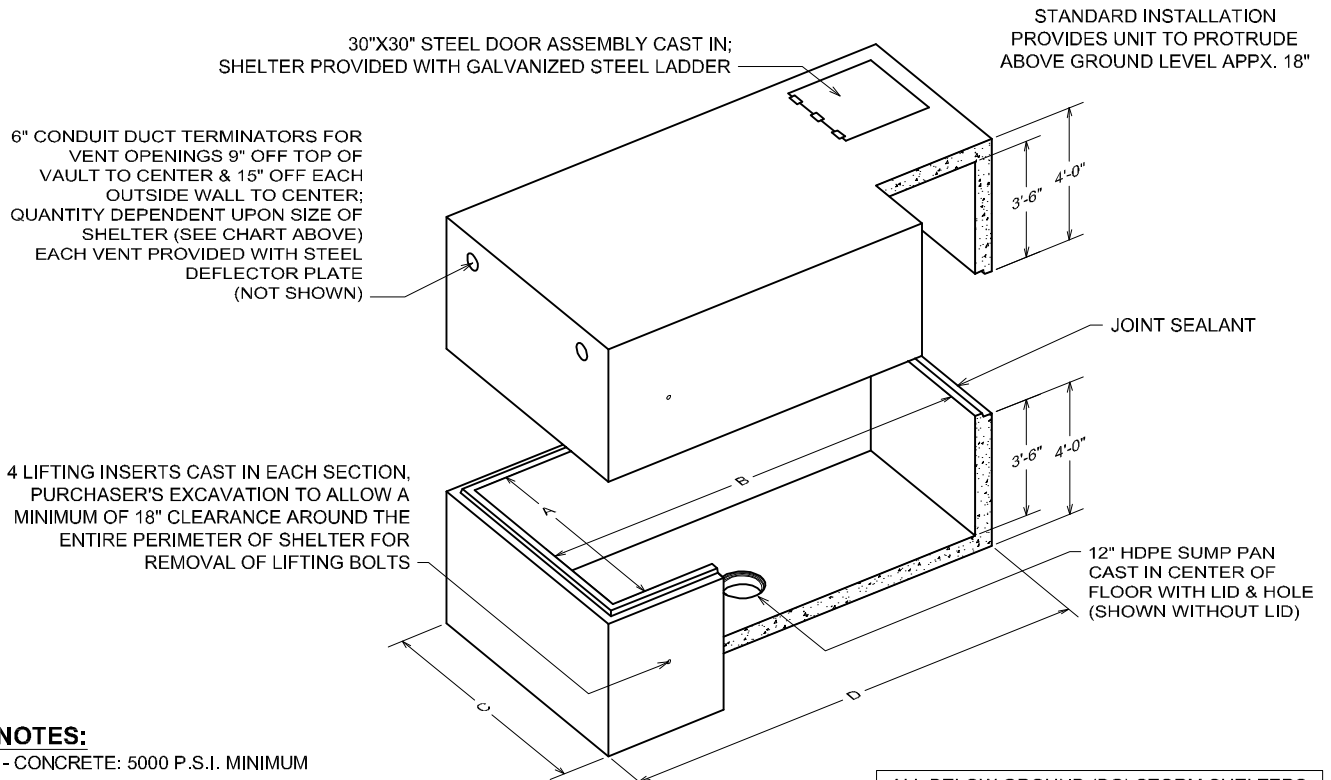

**NOTES:**

- CONCRETE: 5000 P.S.I. MINIMUM
- REINFORCING: GRADE 60 MINIMUM
- \*TOP SECTIONS: #4@12" O.C.E.W. (OR EQUIVALENT STRUCTURAL MESH)
- \*BOTTOM SECTIONS: #5@12" O.C.E.W. (OR EQUIVALENT STRUCTURAL MESH)
- ALL REINFORCING CENTERED IN THE FLOOR, WALLS & ROOF THICKNESS

\*ACTUAL DIMENSIONS OF CONCRETE PRODUCTS MAY VARY SLIGHTLY  
\*PRODUCT & DRAWING SUBJECT TO CHANGE WITHOUT NOTICE

ALL BELOW GROUND (BG) STORM SHELTERS ARE PROVIDED WITH 12" DIAMETER HDPE SUMP PAN WITH DRAIN HOLE; 6" MINIMUM AGGREGATE BASIN TO FACILITATE DRAINAGE TO BE PLACED BELOW EACH SHELTER'S SUMP LOCATION PRIOR TO SETTING IT INTO THE READY EXCAVATION

**vaughn**  
**concrete products, inc.**

DRAWING NOT TO SCALE

SS-RECTANGULAR-BGH.ZWG  
DATE CREATED: 4/07  
UPDATED: 5/07

12650 Tucson Street • Henderson, Colorado 80640 • 303-659-3747, Fax 303-659-1333  
2671 South Greeley Hwy • Cheyenne, Wyoming 82007 • 307-634-0695, Fax 307-634-0694  
10021 Amarillo Blvd East • Amarillo, Texas 79108 • 806-374-3747, Fax 806-335-3717