

Precast Concrete
SEPTIC TANK RISER

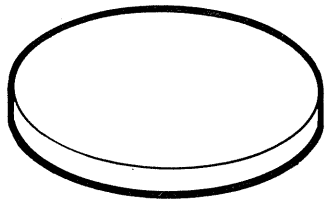

Riser Lid

24" diameter
2" thick
80 lbs.

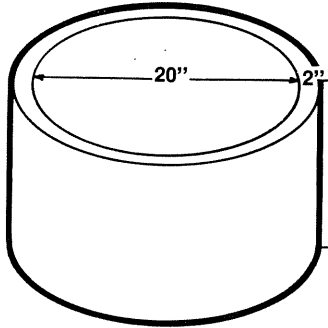

Riser Ring

6"-70 lbs.
12"-140 lbs.
18"-210 lbs.
24"-280 lbs.

Sizes available:

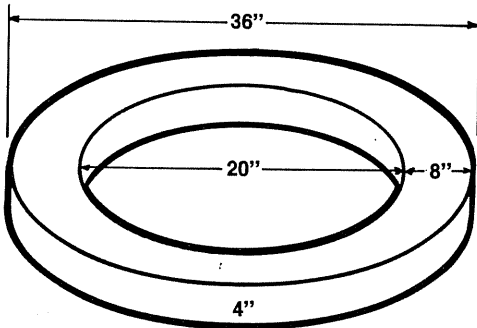

Precast Concrete
Riser Adaptor

For use if septic tank lid openings are larger than 20" in diameter. Install adaptor ring then use our riser rings and lid to bring to ground level.

250 lbs.

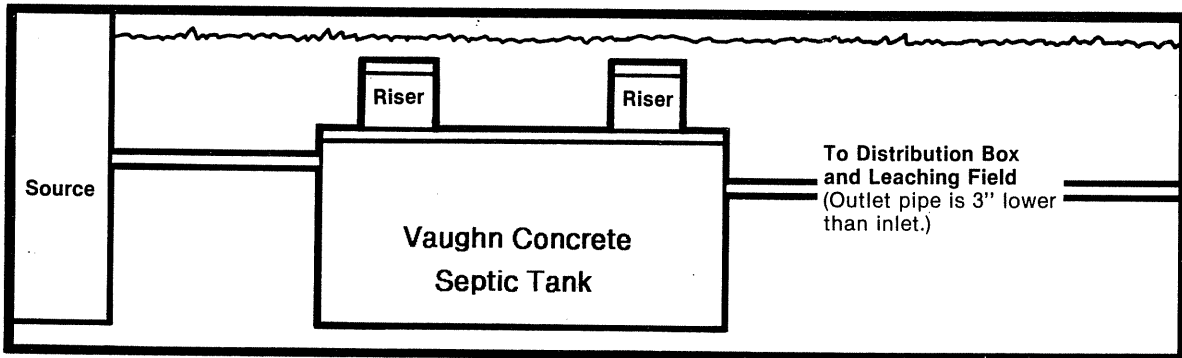

Actual dimensions of concrete products may vary slightly

**Vaughn
concrete products, inc.**

12650 Tucson Street • Henderson, Colorado 80640 • 303-659-3747, Fax 303-659-1333
2671 So. Greeley Hwy • Cheyenne, Wyoming 82007 • 307-634-0695, Fax 307-634-0694
10021 Amarillo Blvd. East • Amarillo, Texas 79107 • 806-374-3747, Fax 806-335-3717