

PRECAST CONCRETE SEPTIC TANK

2000 GALLON CAPACITY, FOR NON-TRAFFIC APPLICATIONS (TX ONLY)

**MONOLITHIC BODY
NO SEAMS OR JOINTS**

4" THICK WALLS & FLOOR, 6" THICK LID

2 COMPARTMENT TANK WITH APPROXIMATELY 60% OF CAPACITY ON INLET SIDE

WITHSTANDS UP TO 6' OF BURY (OPTIONAL RISERS ARE AVAILABLE FOR INLET & OUTLET ACCESSES)

PLAN VIEW

OPTIONS:

- 20" I.D. SEPTIC TANK RISERS
- SEPTIC TANK RISER LIDS
- HEAVIER TRAFFIC RATED LID

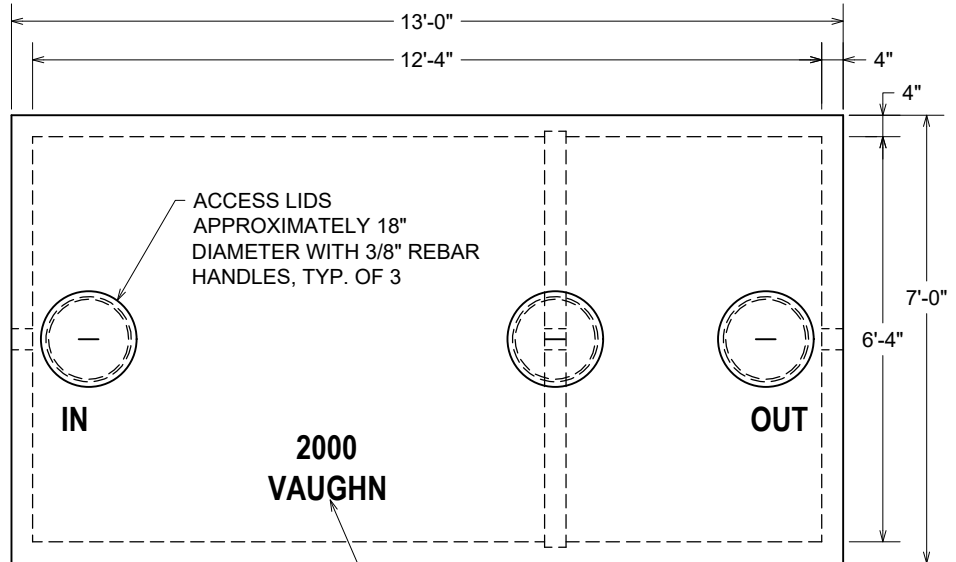

DURING PRODUCTION, "TANK SIZE" & "VAUGHN", "IN" & "OUT" ARE STAMPED IN LID

PIPE SEALS ARE USED ON INLET & OUTLET FOR 4" PIPE

ACCESS LIDS APPROXIMATELY 18" DIAMETER WITH 3/8" REBAR HANDLES, TYP. OF 3

4" PVC CROSS-OVER PIPING INSTALLED PRIOR TO DELIVERY

CONTRACTOR SUPPLIED
4" INLET & OUTLET TEES

SECTION VIEW

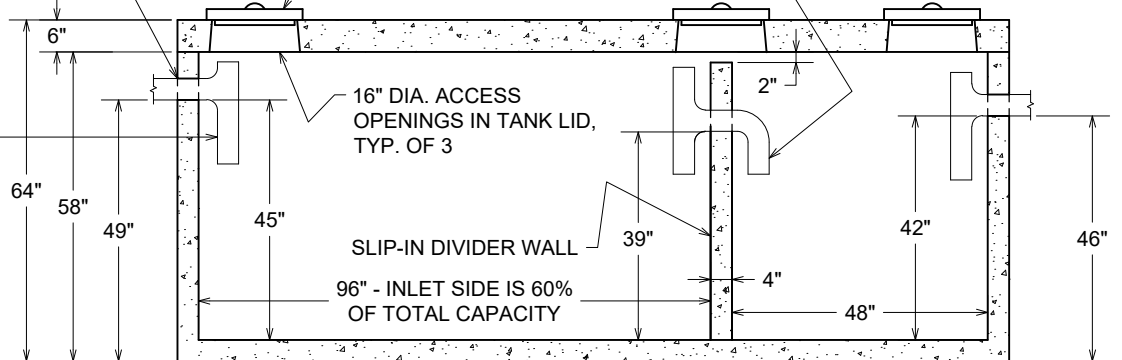

DIGGING SPECIFICATIONS:
- 49" BELOW THE INLET
- EXCAVATION TO BE 9' WIDE X 15' LONG

TANK WEIGHTS:
- TANK LID : 6,850 LBS.
- DIVIDER ONLY : 1,450 LBS.
- TANK WITH DIVIDER ONLY : 16,200 LBS.
- COMPLETE SEPTIC TANK : 23,050 LBS.

CONCRETE : 4,000 P.S.I. (MINIMUM)
REINFORCING : REBAR & WELDED WIRE FABRIC

ACTUAL DIMENSIONS OF CONCRETE PRODUCTS MAY VARY SLIGHTLY

DRAWING NOT TO SCALE

2000 SEPTIC TANK, MONOLITHIC.DWG
DATE CREATED: 10/03
UPDATED: 8/2021

