

PRECAST CONCRETE GREASE INTERCEPTOR

1500 GALLON CAPACITY
FOR NON-TRAFFIC APPLICATIONS
STANDARD FOR TEXAS

IT IS THE EXCAVATOR'S OR INSTALLER'S RESPONSIBILITY TO REQUEST OUR **INSTALLATION GUIDELINES** PRIOR TO INSTALLING THIS TANK

GREASE INTERCEPTOR PREVENTS GREASE FROM ENTERING COMMUNITY SEWAGE COLLECTION SYSTEM & CAUSING FREQUENT LINE PLUGGING

LARGE ACCESS OPENINGS PROVIDE EASIER PUMPING & MAINTENANCE

2 COMPARTMENT TANK WITH APPROXIMATELY 60% OF CAPACITY ON INLET SIDE

WITHSTANDS UP TO 6' OF BURY, RISERS ARE AVAILABLE FOR INLET & OUTLET

OPTIONS:

- 24" I.D. MANHOLE RISERS
- ROOF OF TOP SECTION FOR TRAFFIC LOADINGS
- GAS TIGHT CAST IRON RINGS & COVERS

PIPING KNOCKOUTS 16" FROM END OF TANK TO CENTER OF KNOCKOUT TO ALLOW FOR CONCRETE TO BE BROKEN OUT TO ALLOW FOR SIDE INLET OR OUTLET PIPE AT SAME HEIGHT AS STANDARD INLET & OUTLET, TYP. OF 4

4" THICK WALLS & FLOOR, 5" THICK ROOF
*NOTE: WALLS & DIVIDER DO TAPER, THICKNESSES DO DECREASE TO ALLOW FOR FORM REMOVAL; THE AVG. WALL & DIVIDER THICKNESSES ARE LISTED

OUR STANDARD 24" DIAMETER CAST IRON RINGS & COVERS, TYP. OF 2

24" I.D. MANHOLE RISER AS REQUIRED, TYP. INLET/OUTLET END; AVAILABLE IN 2",3",4",6",8" OR 12" HEIGHTS

CONSEAL JOINT SEALANT, OR CONTRACTOR TO GROUT

PIPING BLOCKOUTS WITH POLYLOK PIPE SEALS CAST IN TANK FOR INLET & OUTLET PIPING (TYPICAL)

CONTRACTOR'S 4" PIPES

CONTRACTOR SUPPLIED
4" SDR35 INLET & OUTLET TEES

CONSEAL JOINT SEALANT

TANK WEIGHTS:

- COMPLETE INTERCEPTOR : 14,000 LBS.

DIGGING SPECIFICATIONS:

- 58" BELOW THE INLET
- EXCAVATION TO BE 6½' WIDE X 14' LONG
- SEE OUR *INSTALLATION GUIDELINES* PRIOR TO INSTALLING THIS TANK

CONCRETE : 4,000 P.S.I. (MINIMUM)
REINFORCING : REBAR & WELDED WIRE FABRIC

ACTUAL DIMENSIONS OF CONCRETE PRODUCTS MAY VARY SLIGHTLY

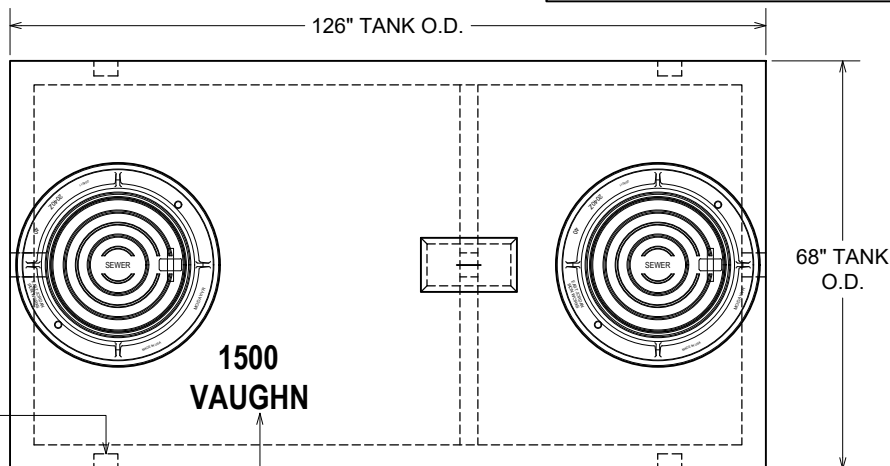

PLAN VIEW

DURING PRODUCTION, "TANK SIZE" & "VAUGHN" ARE STAMPED IN LID, "IN" & "OUT" ARE MARKED ON TANK ENDS

APPROVED BY: _____

DATE: _____

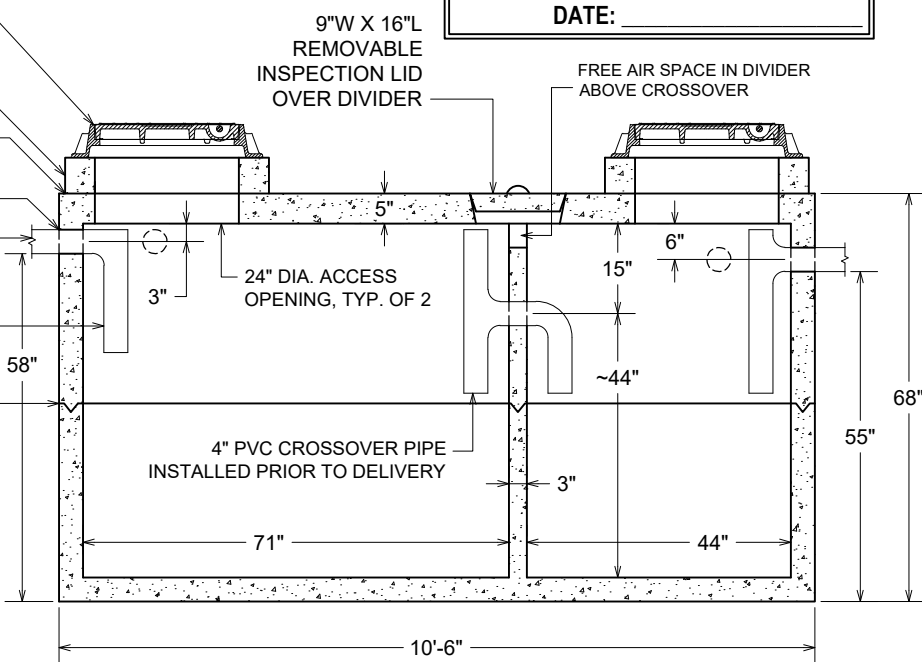

SECTION VIEW

DRAWING IS NOT TO SCALE

1500 GAL. CI, NON-TRAFFIC-TX.DWG
DATE CREATED: 11 / 04
UPDATED: 8 / 2021

