

# PRECAST CONCRETE GREASE INTERCEPTOR

1000 GALLON CAPACITY  
FOR NON-TRAFFIC APPLICATIONS  
STANDARD FOR TEXAS

IT IS THE EXCAVATOR'S OR  
INSTALLER'S RESPONSIBILITY  
TO REQUEST OUR  
**INSTALLATION GUIDELINES**  
PRIOR TO INSTALLING THIS  
TANK

## MONOLITHIC BODY NO SEAMS OR JOINTS

3" THICK FLOOR  
4" THICK WALLS & NON-TRAFFIC LID

2 COMPARTMENT TANK WITH  
APPROXIMATELY 60% OF CAPACITY ON  
INLET SIDE

TANK IS PROVIDED WITH NOTCHES IN  
SIDEWALLS FOR SLIP-IN DIVIDER WALL

WITHSTANDS UP TO 6' OF BURY, RISERS  
ARE AVAILABLE FOR INLET & OUTLET

### OPTIONS:

- 24" I.D. MANHOLE RISERS
- LID SECTION FOR TRAFFIC LOADINGS
- GAS TIGHT CAST IRON RINGS & COVERS

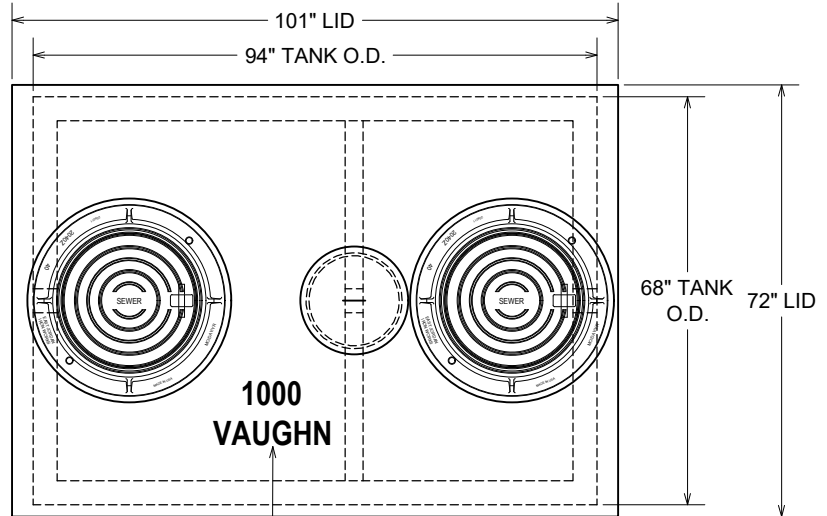

DURING PRODUCTION, "TANK SIZE" &  
"VAUGHN" ARE STAMPED IN LID, "IN" &  
"OUT" ARE MARKED ON TANK ENDS

PLAN VIEW

OUR STANDARD 24" DIAMETER CAST  
IRON RINGS & COVERS, TYP. OF 2

24" I.D. MANHOLE RISER AS REQUIRED,  
TYP. INLET/OUTLET END; AVAILABLE IN  
2", 3", 4", 6", 8" & 12" HEIGHTS

CONSEAL JOINT SEALANT, OR  
CONTRACTOR TO GROUT

PIPING BLOCKOUTS WITH POLYLOK  
PIPE SEALS CAST IN TANK FOR INLET  
& OUTLET PIPING (TYPICAL)

CONTRACTOR'S 4" PIPES

CONTRACTOR SUPPLIED  
4" SDR35 INLET & OUTLET TEES

18" DIA. REMOVABLE  
INSPECTION LID  
OVER DIVIDER

APPROVED BY: \_\_\_\_\_

DATE: \_\_\_\_\_

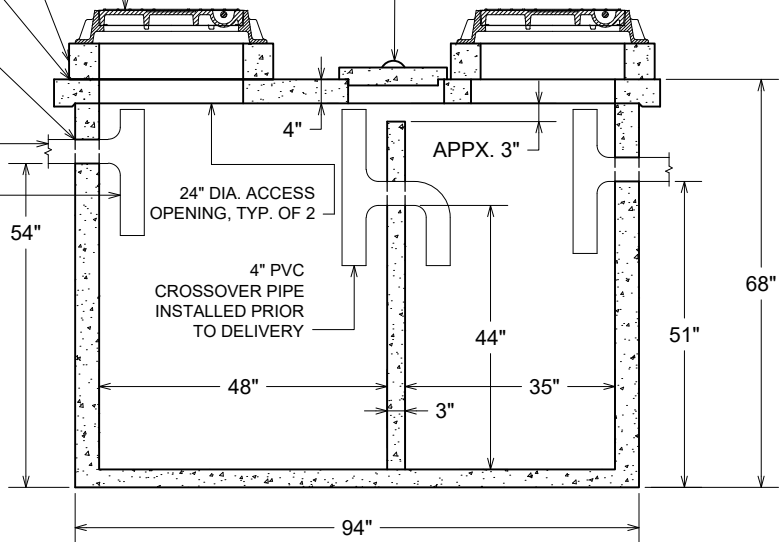

SECTION VIEW

### TANK WEIGHTS:

- TANK LID : 2,800 LBS.
- TANK WITH DIVIDER ONLY : 8,000 LBS.
- COMPLETE INTERCEPTOR : 10,800 LBS.

### DIGGING SPECIFICATIONS:

- 54" BELOW THE INLET
- EXCAVATION: 7'-0" WIDE X 10'-0" LONG
- SEE OUR **INSTALLATION GUIDELINES**  
PRIOR TO INSTALLING THIS TANK

CONCRETE : 4,000 P.S.I. (MINIMUM)  
REINFORCING : REBAR & WELDED WIRE FABRIC

ACTUAL DIMENSIONS OF CONCRETE PRODUCTS MAY VARY SLIGHTLY

DRAWING IS NOT TO SCALE

1000 GAL. GI, NON-TRAFFIC-TX.DWG  
DATE CREATED: 11 / 04  
UPDATED: 8 / 2021

# vaughn concrete products, inc.

10021 Amarillo Blvd East • Amarillo, Texas 79108 • 806-374-3747, Fax 806-335-3717

[www.vaughnconcreteproducts.com](http://www.vaughnconcreteproducts.com)