

ANGLE FRAME, HEAVY DUTY, SINGLE DOOR - ALUMINUM

This drawing is the sole property of U.S.F. Fabrication, Inc. and is for illustrative purposes only.

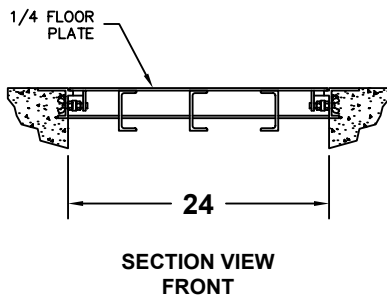
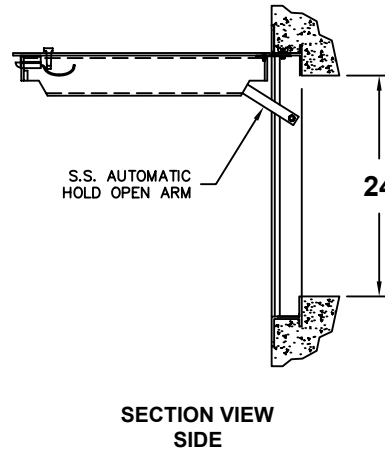
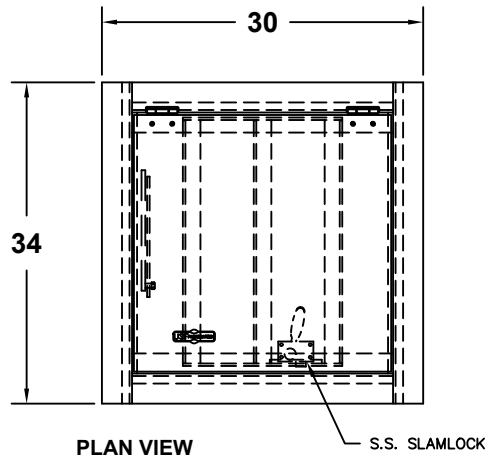

USED ON METER VAULTS

VCP DESIGNATION: 24X24 AHS ALUMINUM TRAFFIC HATCH

NOTES:

Weight: 59 lbs. (approx. hatch base weight w/o options)

NOTES:

- 1- MATERIAL: ALUMINUM
- 2- LOADING: DESIGNED FOR OFF STREET LOCATIONS WHICH MAY OCCASIONALLY RECEIVE H-20 WHEEL LOADS.
- 3- 316 STAINLESS STEEL BOLTS, HINGES AND HOLD OPEN ARM

U.S.F. FABRICATION INC.
FLOOR ACCESS DOORS, GRATING AND MISC. METAL FABRICATION



AHS AASHTO H-20 24" x 24"
CLEAR OPENING: 22" x 23"

FROM:	QUOTE#	DATE:
WEB ID: 556	7397	10/31/2006