

PRECAST CONCRETE GREASE INTERCEPTOR

1250 GALLON CAPACITY
FOR NON-TRAFFIC APPLICATIONS
STANDARD FOR COLORADO & WYOMING

IT IS THE EXCAVATOR'S OR
INSTALLER'S RESPONSIBILITY
TO REQUEST OUR
INSTALLATION GUIDELINES
PRIOR TO INSTALLING THIS
TANK

GREASE INTERCEPTOR PREVENTS
GREASE FROM ENTERING COMMUNITY
SEWAGE COLLECTION SYSTEM & CAUSING
FREQUENT LINE PLUGGING

LARGE ACCESS OPENINGS PROVIDE
EASIER PUMPING & MAINTENANCE

2 COMPARTMENT TANK WITH
APPROXIMATELY 60% OF
CAPACITY ON INLET SIDE

WITHSTANDS UP TO 6' OF BURY,
RISERS ARE AVAILABLE FOR
INLET & OUTLET

OPTIONS:

- 24" I.D. MANHOLE RISERS
- ROOF OF TOP SECTION FOR TRAFFIC LOADINGS
- GAS TIGHT CAST IRON RINGS & COVERS

PIPING KNOCKOUTS 16" FROM END OF
TANK TO CENTER OF KNOCKOUT TO
ALLOW FOR CONCRETE TO BE BROKEN
OUT TO ALLOW FOR SIDE INLET OR
OUTLET PIPE AT SAME HEIGHT AS
STANDARD INLET & OUTLET, TYP. OF 4

4" THICK WALLS & FLOOR, 5" THICK ROOF
*NOTE: WALLS & DIVIDER DO TAPER,
THICKNESSES DO DECREASE TO ALLOW FOR
FORM REMOVAL; THE AVG. WALL & DIVIDER
THICKNESSES ARE LISTED

OUR STANDARD 24" DIAMETER CAST
IRON RINGS & COVERS, TYP. OF 2

24" I.D. MANHOLE RISER AS REQUIRED,
TYP. INLET/OUTLET END; AVAILABLE IN
2",3",4",6",8" OR 12" HEIGHTS

CONSEAL JOINT SEALANT, OR
CONTRACTOR TO GROUT

PIPING BLOCKOUTS WITH POLYLOK
PIPE SEALS CAST IN TANK FOR INLET
& OUTLET PIPING (TYPICAL)

CONTRACTOR'S 4" PIPES
CONTRACTOR SUPPLIED
4" SDR35 INLET & OUTLET TEES

CONSEAL JOINT SEALANT

TANK WEIGHTS:

- COMPLETE INTERCEPTOR : 12,700 LBS.

DIGGING SPECIFICATIONS:

- 54" BELOW THE INLET
- EXCAVATION TO BE 6½' WIDE X 12' LONG
- SEE OUR *INSTALLATION GUIDELINES*
PRIOR TO INSTALLING THIS TANK

CONCRETE : 4,000 P.S.I. (MINIMUM)
REINFORCING : REBAR & WELDED WIRE FABRIC

ACTUAL DIMENSIONS OF CONCRETE PRODUCTS MAY VARY SLIGHTLY

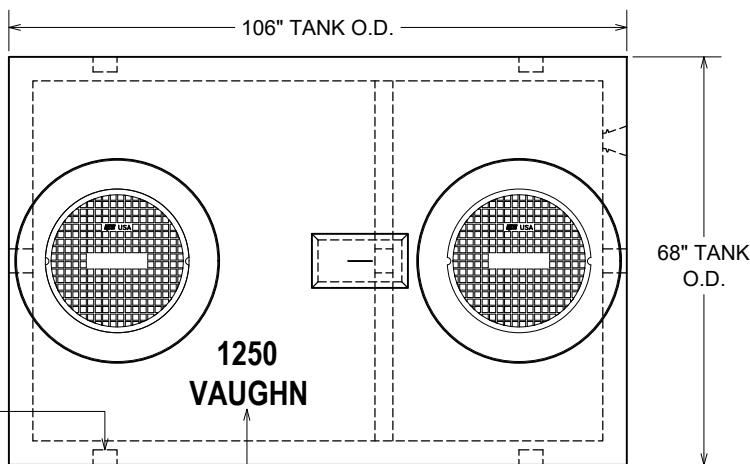

PLAN VIEW

DURING PRODUCTION, "TANK SIZE" &
"VAUGHN" ARE STAMPED IN LID, "IN" &
"OUT" ARE MARKED ON TANK ENDS

APPROVED BY: _____

DATE: _____

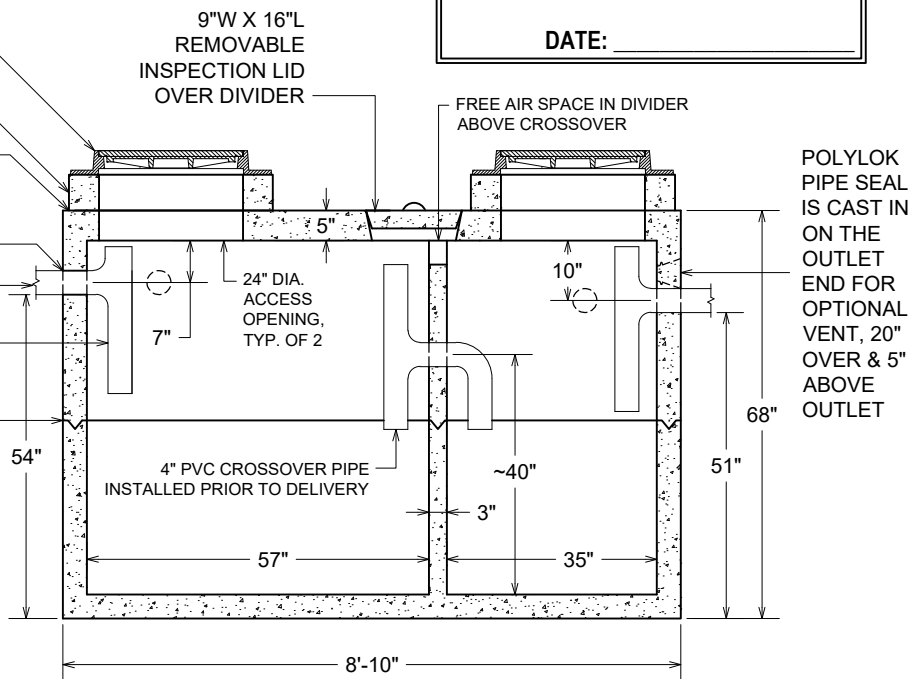

SECTION VIEW

DRAWING IS NOT TO SCALE

1250 GAL. GI, NON-TRAFFIC.DWG
DATE CREATED: 11 / 04
UPDATED: 8 / 2021

vaughn
concrete products, inc.

12650 Tucson Street • Henderson, Colorado 80640 • 303-659-3747, Fax 303-659-1333
2671 South Greeley Hwy • Cheyenne, Wyoming 82007 • 307-634-0695, Fax 307-634-0694

www.vaughnconcreteproducts.com