

PRECAST CONCRETE

TRANSFORMER PAD #VCP393

100" WIDE X 91" LONG X 8" THICK

VCP ITEM #VCP393

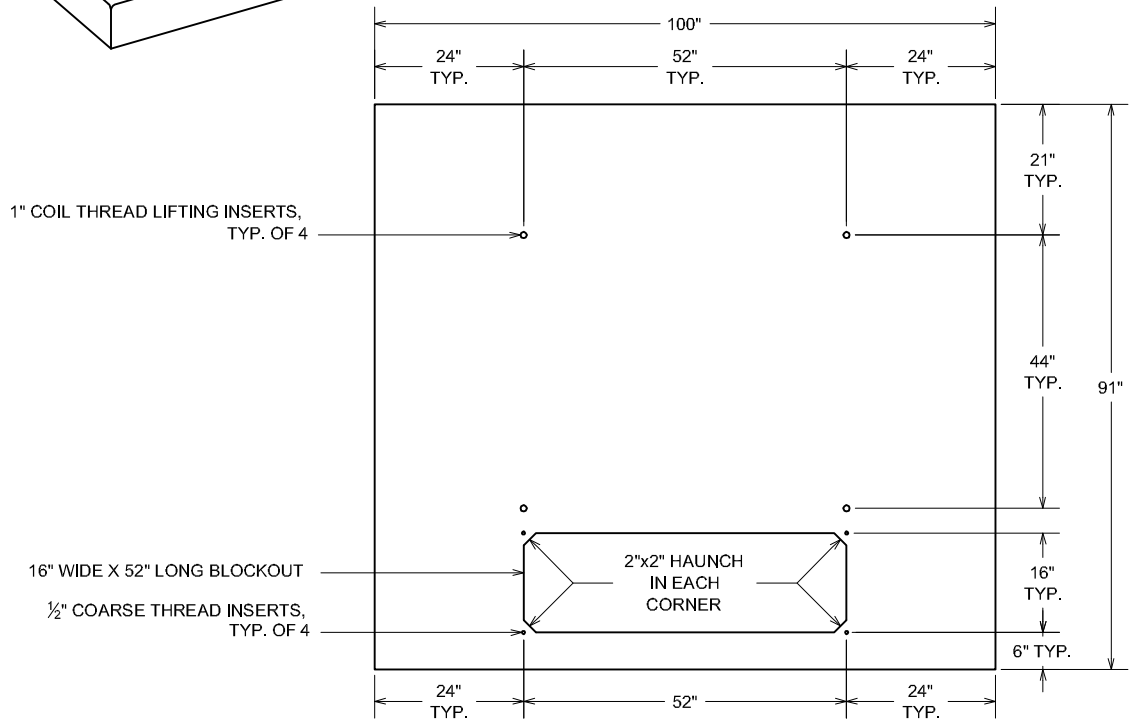
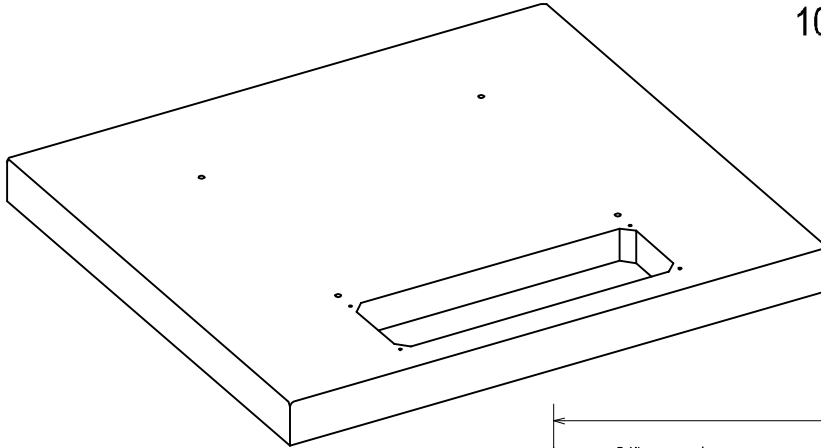

1" COIL THREAD LIFTING INSERTS,
TYP. OF 4

16" WIDE X 52" LONG BLOCKOUT
1/2" COARSE THREAD INSERTS,
TYP. OF 4

PLAN VIEW

ENTIRE TOP PERIMETER EDGE
ROUNDED WITH CONCRETE EDGER

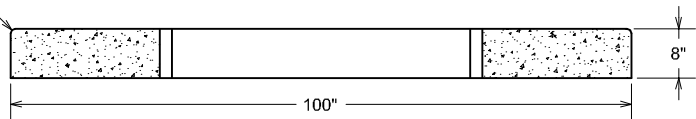

SECTION VIEW

WEIGHT:

- PAD WEIGHS APPX. 5,700 LBS.

NOTES:

- CONCRETE: 4000 P.S.I. MINIMUM
- REINFORCING: GRADE 60 MINIMUM

ACTUAL DIMENSIONS OF CONCRETE PRODUCTS MAY VARY SLIGHTLY

LIFTING DETAILS:

PAD TO LIFT WITH:

- (4) 1" COIL BOLTS
- (4) SWIVEL PLATES OR LIFT ANGLES FOR 1" COIL BOLTS

DRAWING NOT TO SCALE

TRANSFORMER PAD, #VCP393, DWG
DATE CREATED: 12/08
UPDATE: -----

vaughn concrete products, inc.

12650 Tucson Street • Henderson, Colorado 80640 • 303-659-3747, Fax 303-659-1333
2671 South Greeley Hwy • Cheyenne, Wyoming 82007 • 307-634-0695, Fax 307-634-0694
10021 Amarillo Blvd East • Amarillo, Texas 79108 • 806-374-3747, Fax 806-335-3717