

PRECAST CONCRETE

# TRANSFORMER PAD #VCP392

73" WIDE X 84" LONG X 6" THICK

VCP ITEM #VCP392

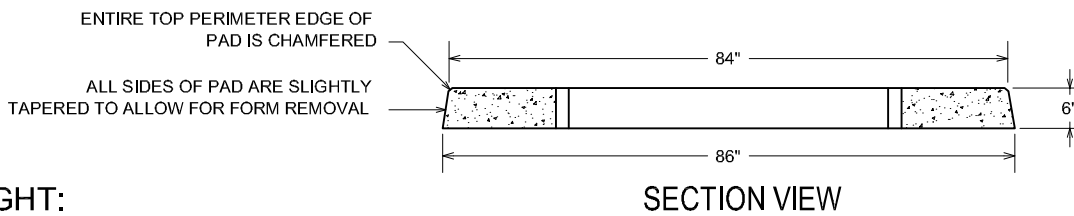
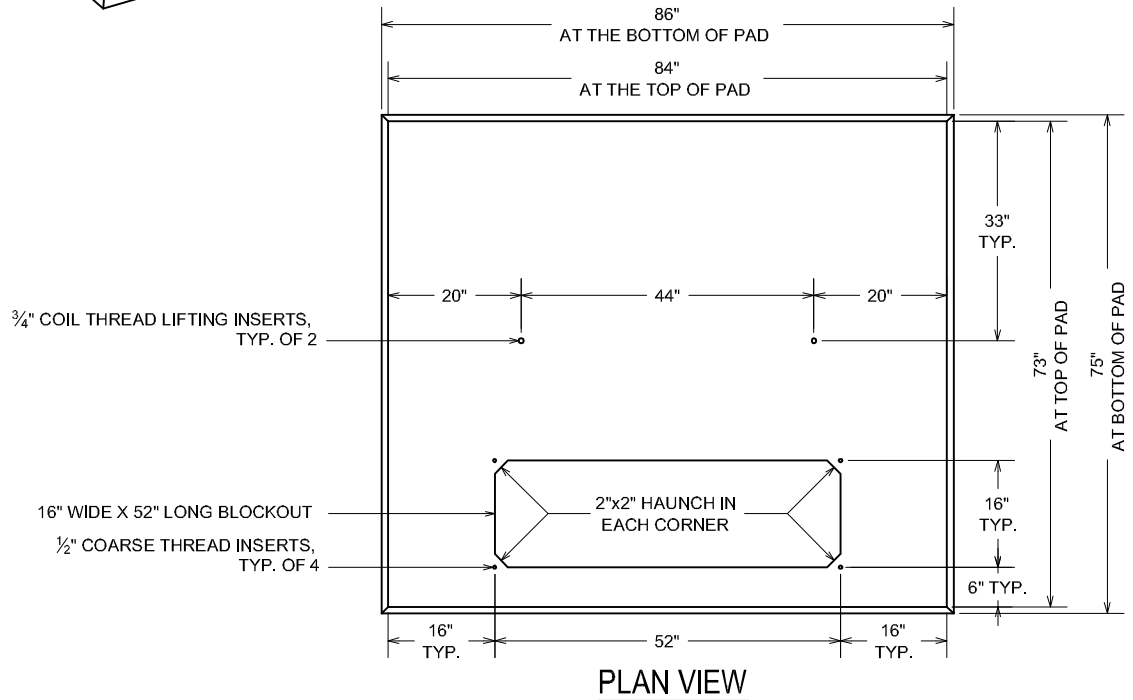
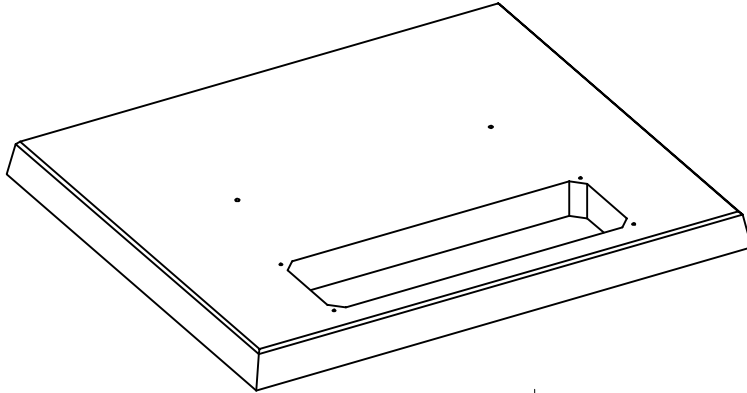

**WEIGHT:**

- PAD WEIGHS APPX. 2,800 LBS.

**NOTES:**

- CONCRETE: 4000 P.S.I. MINIMUM
- REINFORCING: GRADE 60 MINIMUM

ACTUAL DIMENSIONS OF CONCRETE PRODUCTS MAY VARY SLIGHTLY

**LIFTING DETAILS:**

PAD TO LIFT WITH:

- (2) 3/4" COIL BOLTS
- (2) SWIVEL PLATES OR LIFT ANGLES FOR 3/4" COIL BOLTS

DRAWING NOT TO SCALE

TRANSFORMER PAD, #VCP392.DWG  
DATE CREATED: 12/08  
UPDATED: -----



12650 Tucson Street • Henderson, Colorado 80640 • 303-659-3747, Fax 303-659-1333  
 2671 South Greeley Hwy • Cheyenne, Wyoming 82007 • 307-634-0695, Fax 307-634-0694  
 10021 Amarillo Blvd East • Amarillo, Texas 79108 • 806-374-3747, Fax 806-335-3717